

***Development of a Multi-Channel Integrated
Circuit for Use in Nuclear Physics Experiments
Where Particle Identification is Important***

Michael Hall

Southern Illinois University Edwardsville

IC Design Research Laboratory

April 3, 2007

Design Team

Southern Illinois University Edwardsville:

- Dr. George Engel (PI)
- Michael Hall (graduate student)
- Justin Proctor (graduate student)
- Venkata Tirumasaletty (graduate student)

Washington University in St. Louis:

- Dr. Lee Sobotka (Co-PI)
- Jon Elson (electronics specialist)
- Dr. Robert Charity

Western Michigan:

- Dr. Mike Famiano (Co-PI)

Research Objective

- Design a custom microchip which can be used by nuclear physicists when they perform experiments.
- In these experiments, physicists use detectors to sense radiation.
- These experiments often require that the physicists identify the type of radiation (α particle, γ -ray, etc) that struck the detector.

NSF Proposal (Funded)

- \$200,000 grant funded from September 2006 to August 2008.
- Design, simulate, and fabricate a custom integrated circuit for particle identification suitable for use with
 - CsI(Tl) (used for charge-particle discrimination)
 - Liquid Scintillator (used for neutron-gamma discrimination)
- 8 channel “prototype” chip
- 16 channel “production” chip

Intended Applications

- The chip will be used in an experiment at the National Superconducting Cyclotron Laboratory (NSCL) in Fall 2007 by Washington University collaborators.
- Mass production of PSD technology is actively being sought by our government's Department of Homeland Security.

Chip and Sensor Array

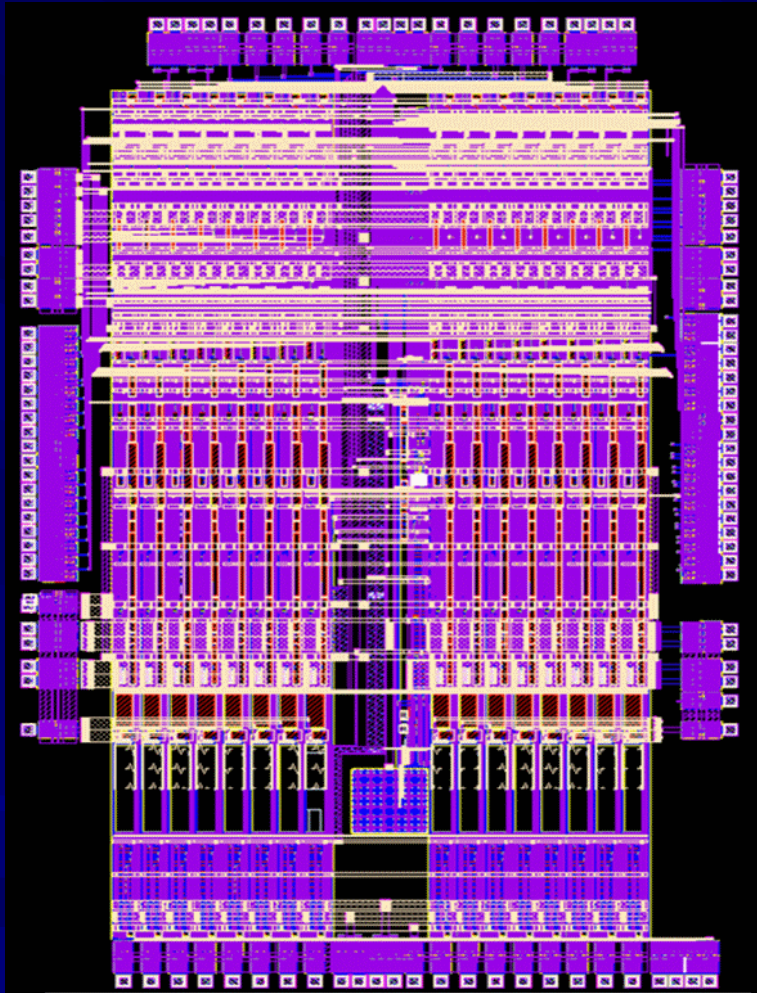

Earlier IC developed in our lab currently being used in Physics experiments around the country

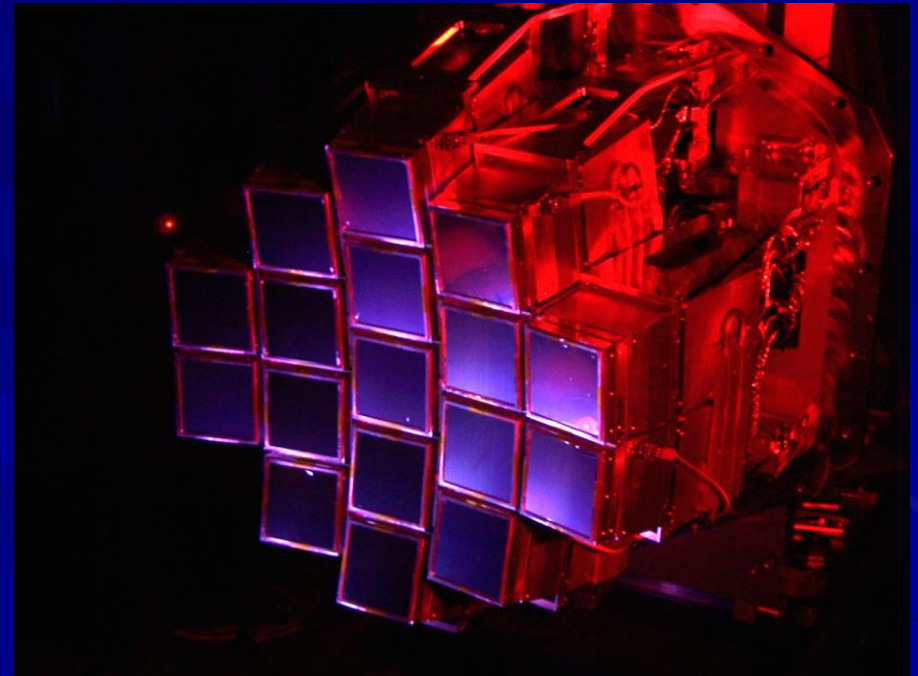

HiRA Detector Array at MSU

Simulated Input Pulse for CsI(Tl) Detector

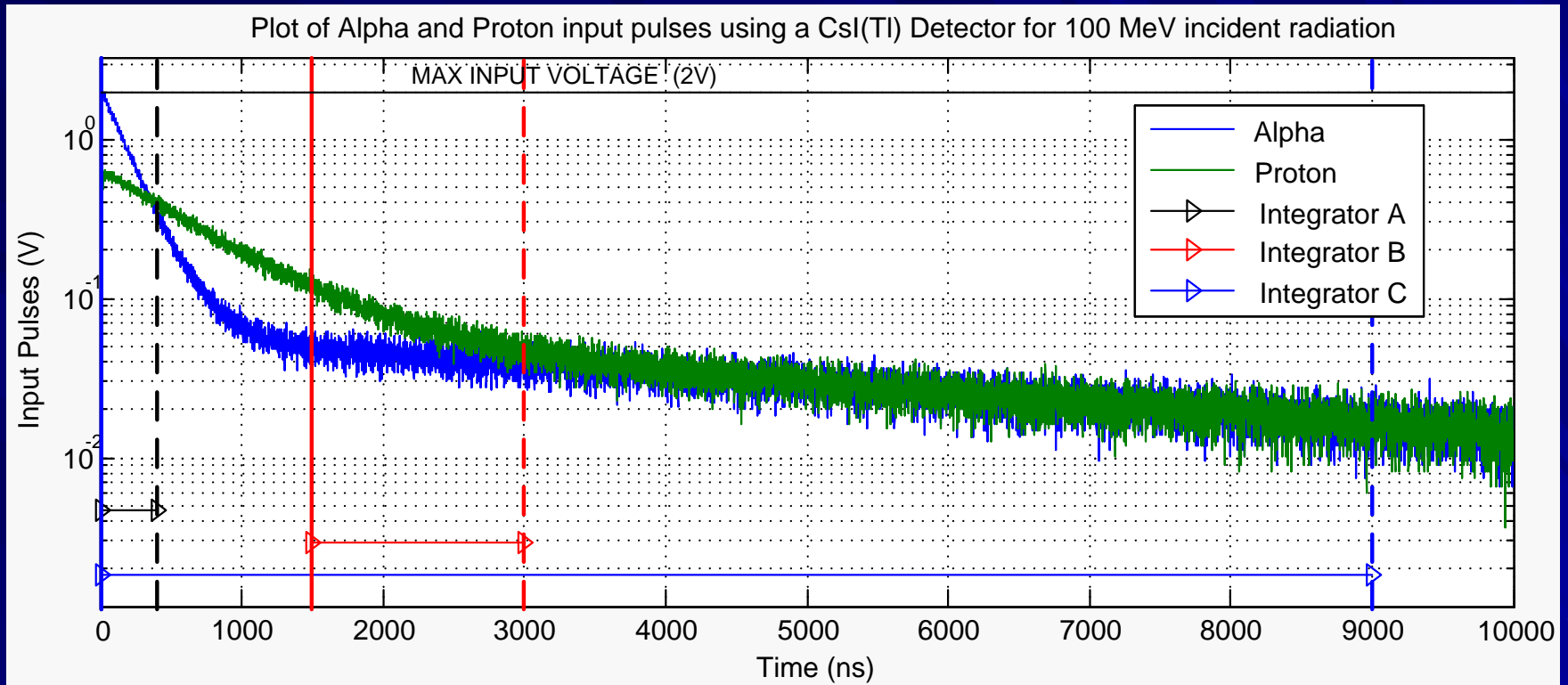

■ Integrators

- A 0 to 400 ns
- B 1500 to 1500 ns
- C 0 to 9000 ns

- Integration periods at the beginning of the signal are assumed to start before the pulse (at -5 ns).

Need for an Integrated Circuit

- Particle identification (α particle, γ -ray, *etc.*) capability
- Ability to support multiple (*i.e.* initially eight but eventually sixteen) radiation detectors
- Three separate integration regions with independent control of charging rate in each region which can be used for high-quality pulse shape discrimination (PSD).
- Built-in high-quality timing circuitry
- Multiple (3) triggering modes
- Data sparsification

Overview of PSD System

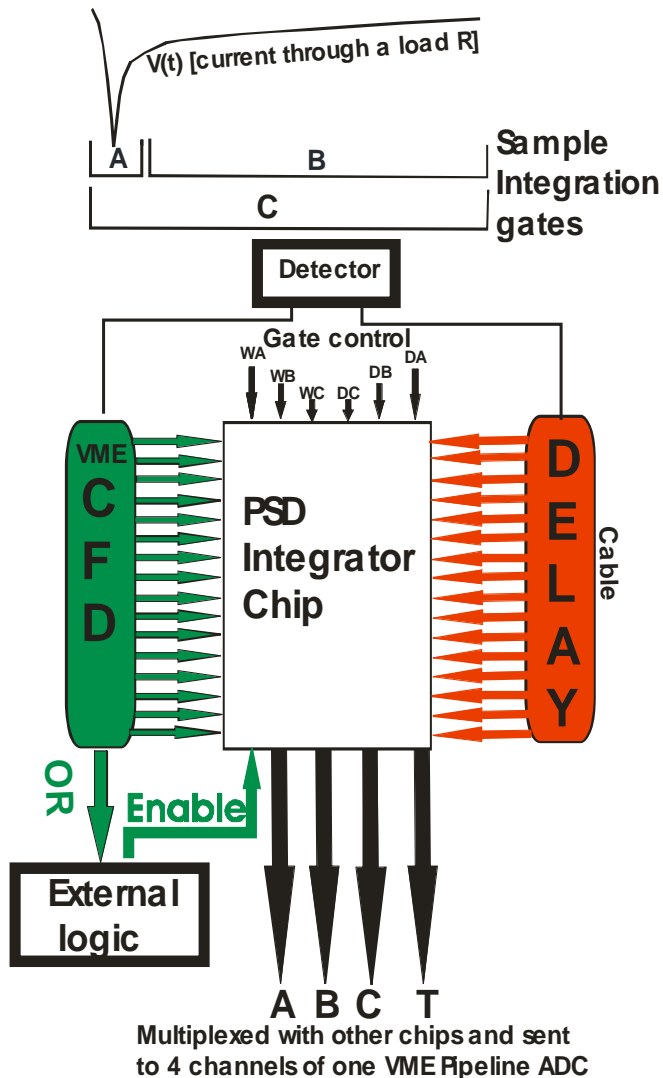

- Detector (PMT or photodiode)
- External discriminators (CFDs)
- External delay lines so we can start integrations before arrival of pulse
- External control voltages determine **D**elay and **W**idth of integration periods
- Outputs A, B, C integrator voltages and relative time, T

Channel

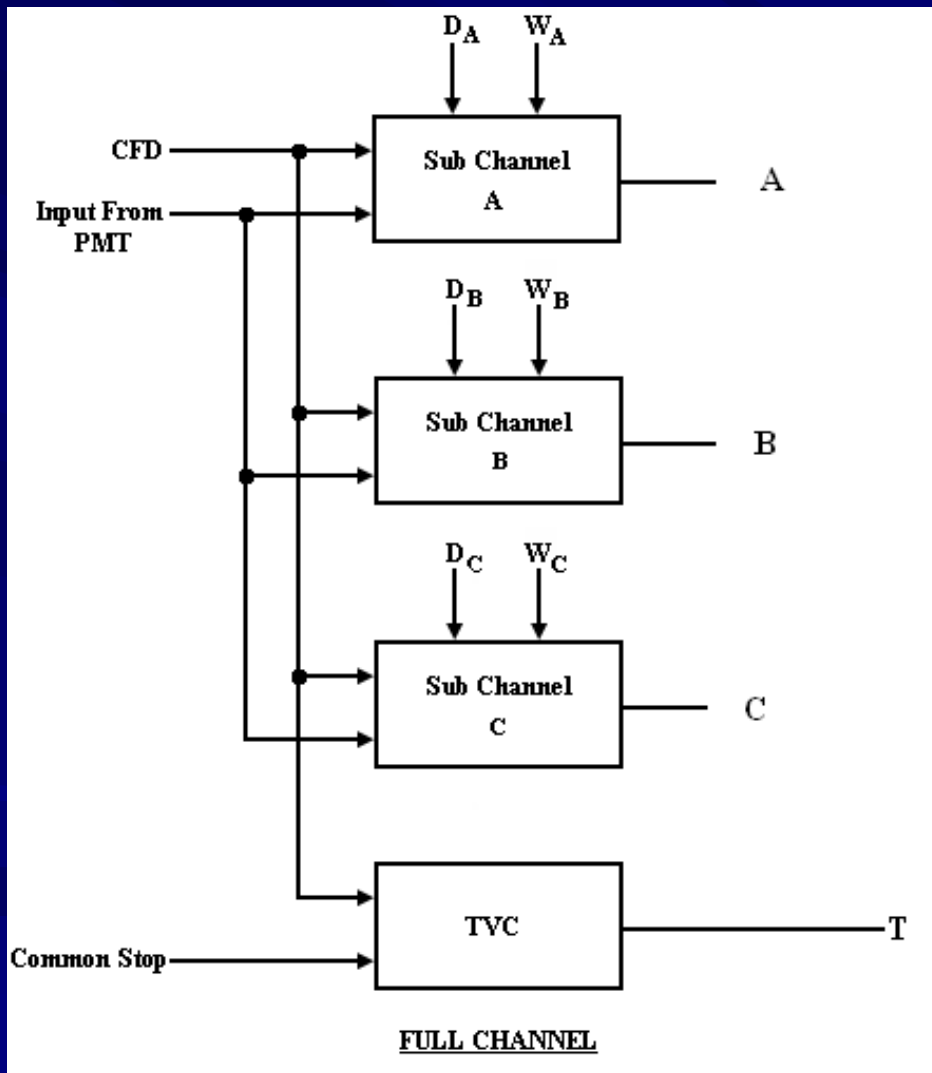

- 3 on-chip sub-channels for integrators A, B, C
- Delay and width of integrators set by externally supplied control voltages
- Timing relative to a common stop signal

Sub-Channel

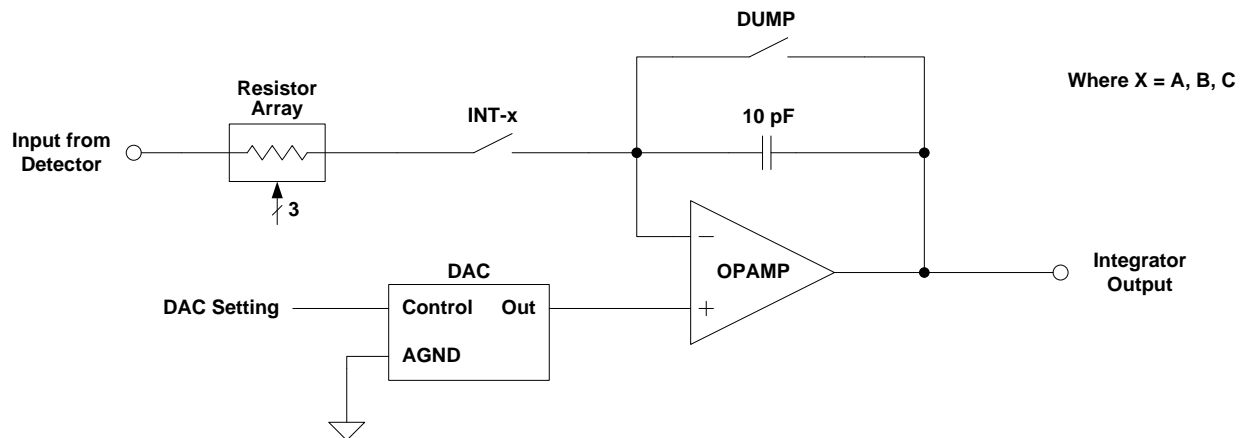
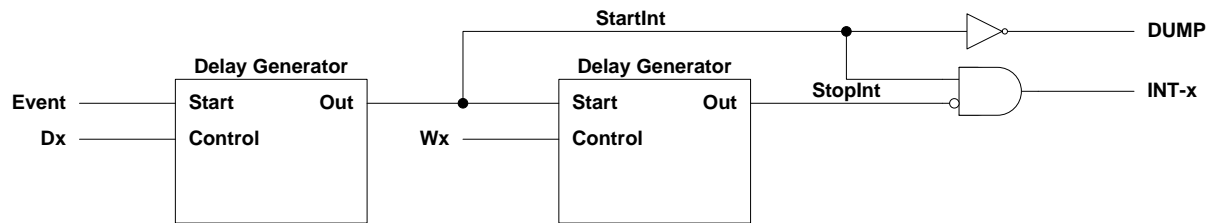
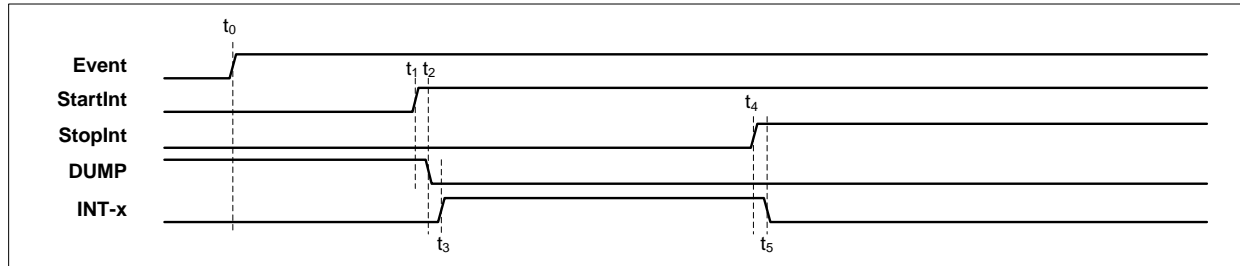

SUB CHANNEL

Pulse Shape Discrimination Plot for CsI(Tl) Detector

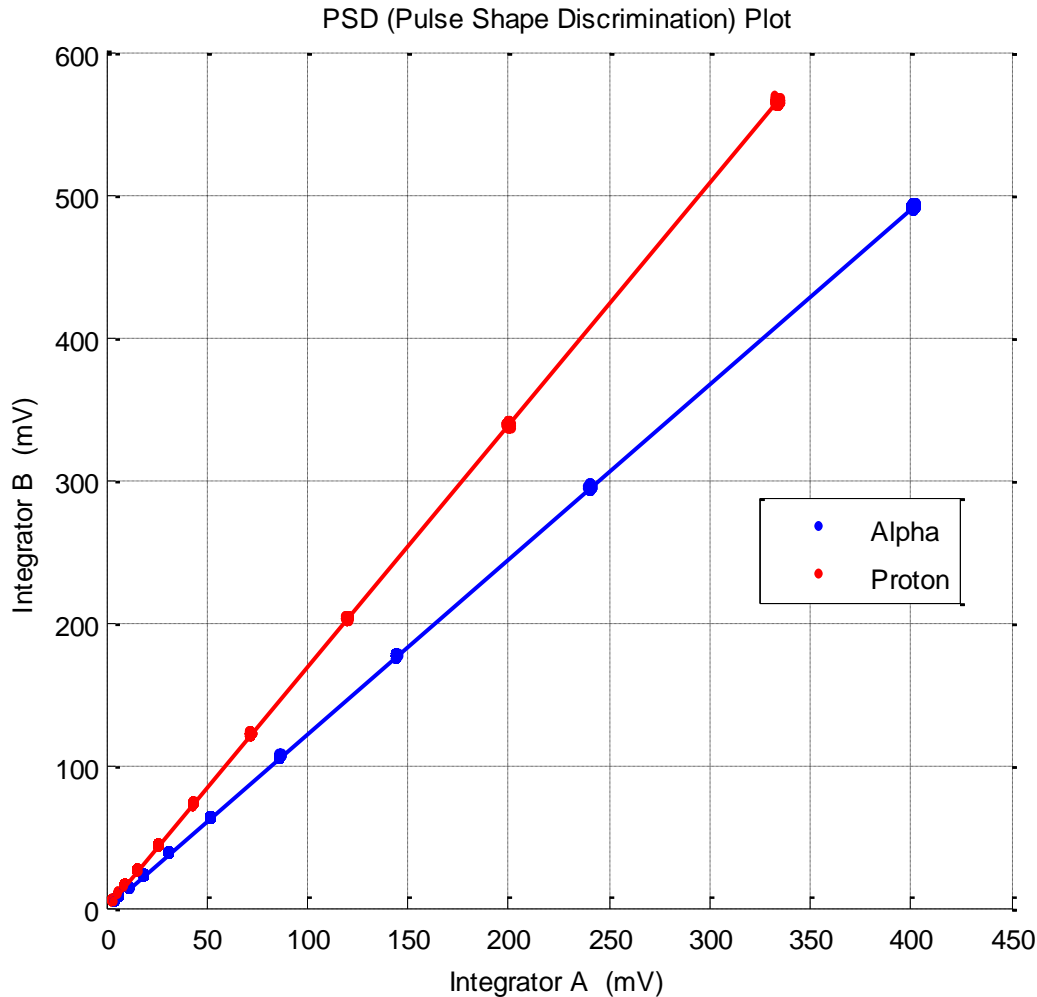

- Detector: CsI(Tl)
- Integrators: A, B
- Energy Max: 100 MeV (for 2V at input of integrator)
- Energy Range: 1 – 100 MeV
- Includes all noise sources

Angular PSD Plots (CsI)

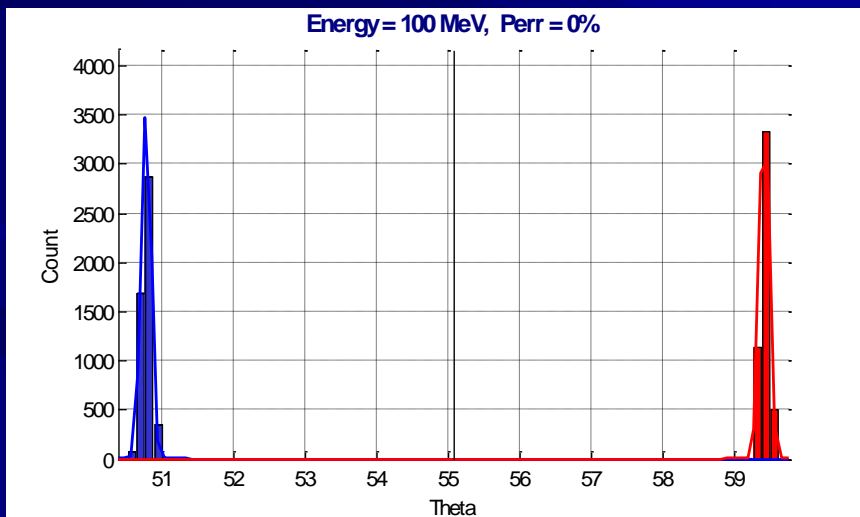
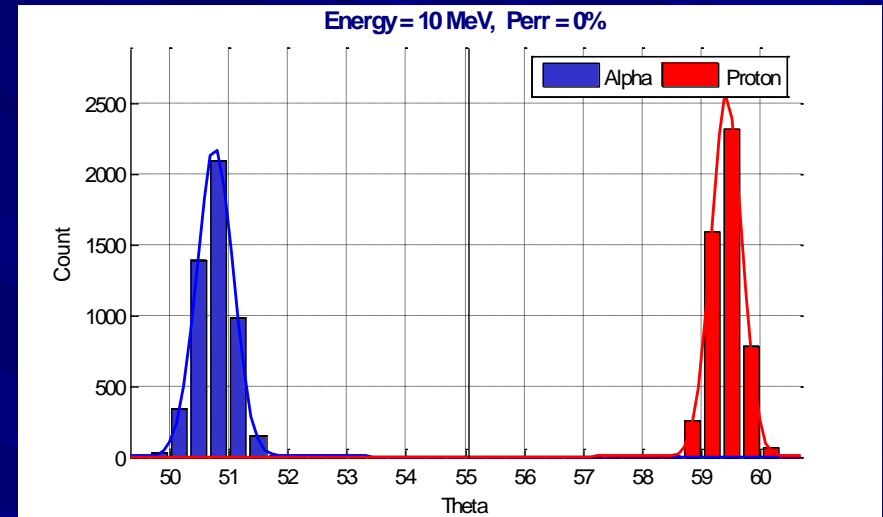
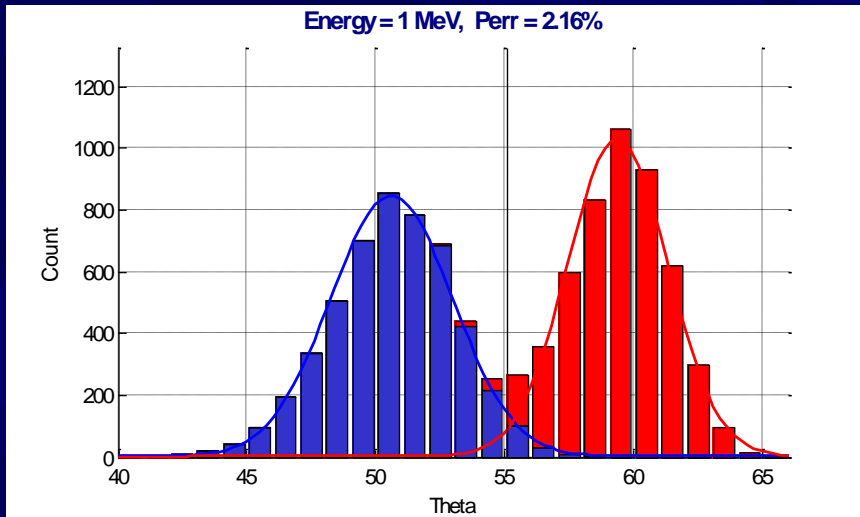

- Detector: CsI(Tl)
- Integrators: A, B
- Energy Max: 100 MeV
- Energy Range: 1 – 100 MeV
- 5000 realizations
- Includes all noise sources

Current Work

- Circuit design and simulations
- Behavioral level simulations (VerilogA) to verify functionality of one complete channel including read-out electronics

Future Work

- Layout
- Fabrication
 - Chip should leave for fabrication in August 2007.
 - Will take approximately 2 months to make.
- Testing of the IC
- Chip will be used in experiment at NSCL in Fall 2007